



# The ROSA Process

Advances in TCA reduction



AMORIM

Technical presentation by  
Prof. Miguel Cabral  
Director of Research & Development  
Amorim & Irmãos



# PREVENTIVE STRATEGY – RECENT INNOVATIONS

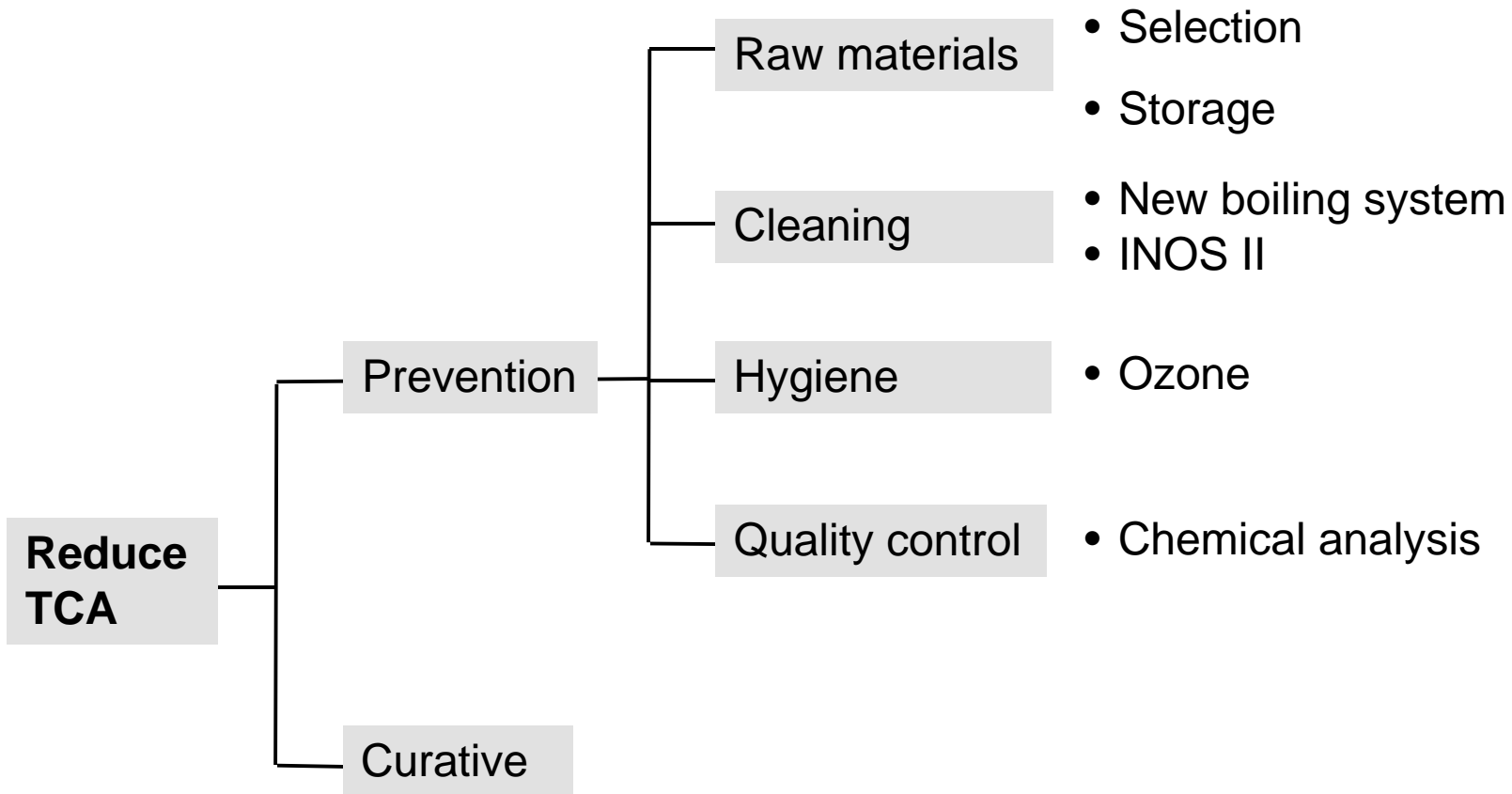



AMORIM

## STRICT SCIENTIFIC METHODOLOGY FOR TCA ANALYSIS

- Validate method
- Use control standards to produce quality charts
- Inter-laboratory tests



AMORIM

## VALIDATION OF METHOD: EG DETECTION AND QUANTIFICATION LIMITS

	<b>Detection limit (ng/l)</b>	<b>Quantification limit (ng/l)</b>
<b>GC-ECD 1</b>	0.6	2.0
<b>GC-ECD 2</b>	0.5	1.5
<b>GC-MS</b>	0.5	1.7



AMORIM

# CONTROL CHARTS

## 25 JULY – 26 SEPTEMBER 2003

Control Chart MS (3ppt)

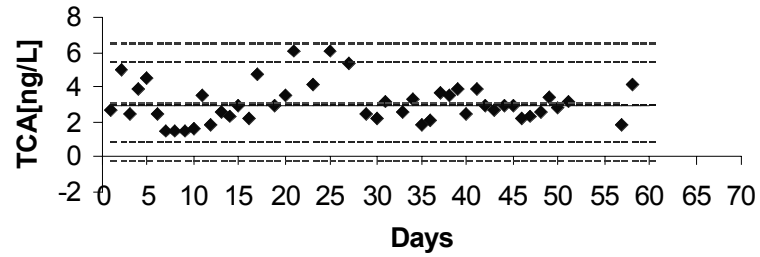

Control Chart MS (5 ppt)

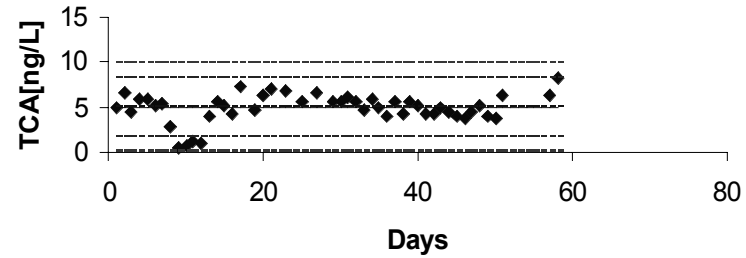

Control Chart ECD1 (3 PPT)

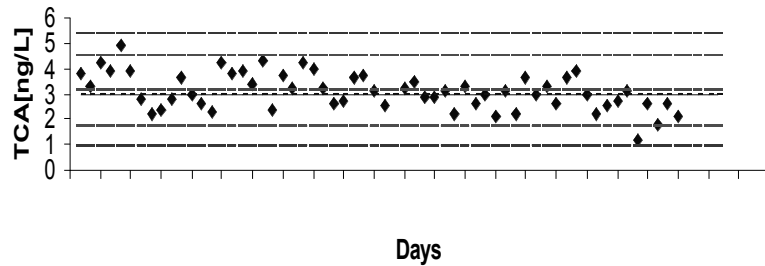

Control Chart ECD1 (5 PPT)

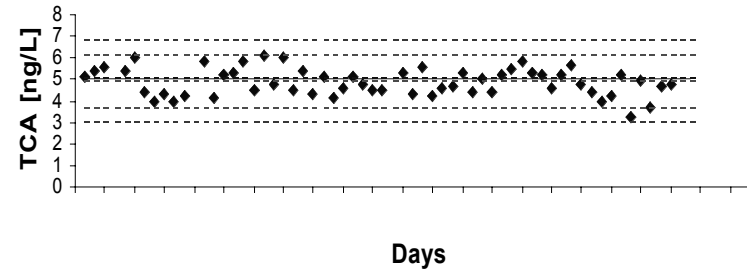



AMORIM

## CURRENT INTER-LABORATORY TESTS, OCTOBER 2003

- Sporadic ring tests since September 2001
- Systematic ring tests since July 2003
  - Organised by Laboratoire Excell
    - Commenced July 2003
    - Excell, ETS, Amorim, Sabaté
  - Organised by Laboratoire CEVAQOE
    - Commenced September 2003



AMORIM

## EFFECTIVENESS OF QUALITY CONTROL

- 5 units (GC-MS, GC-ECD)
- More than 5000 samples per month

- TCA claims at all time low



AMORIM

## EFFECTIVENESS OF AMORIM PROCESSING — CASE STUDY

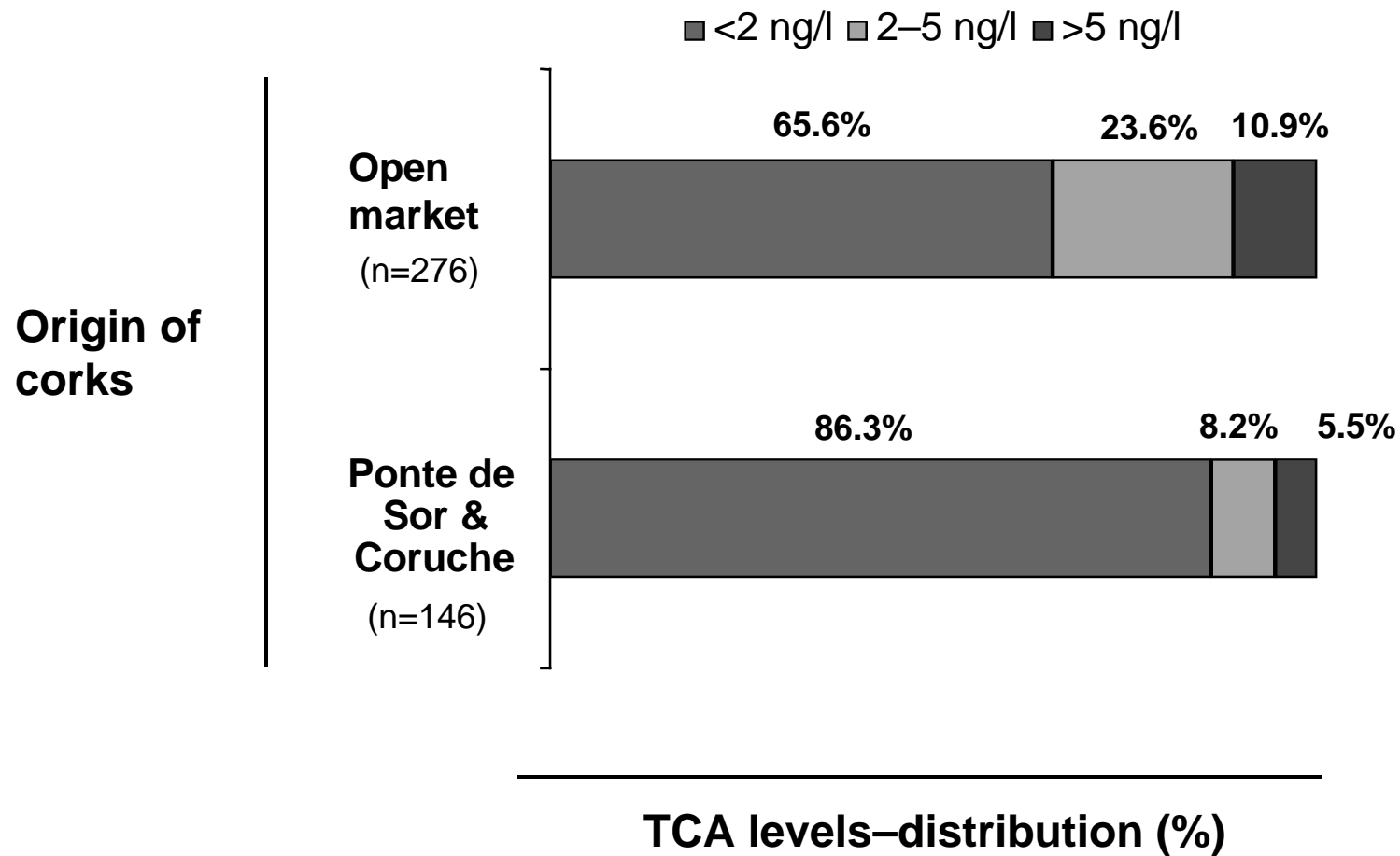



AMORIM

## PREVENTIVE STRATEGY – RECENT INNOVATIONS

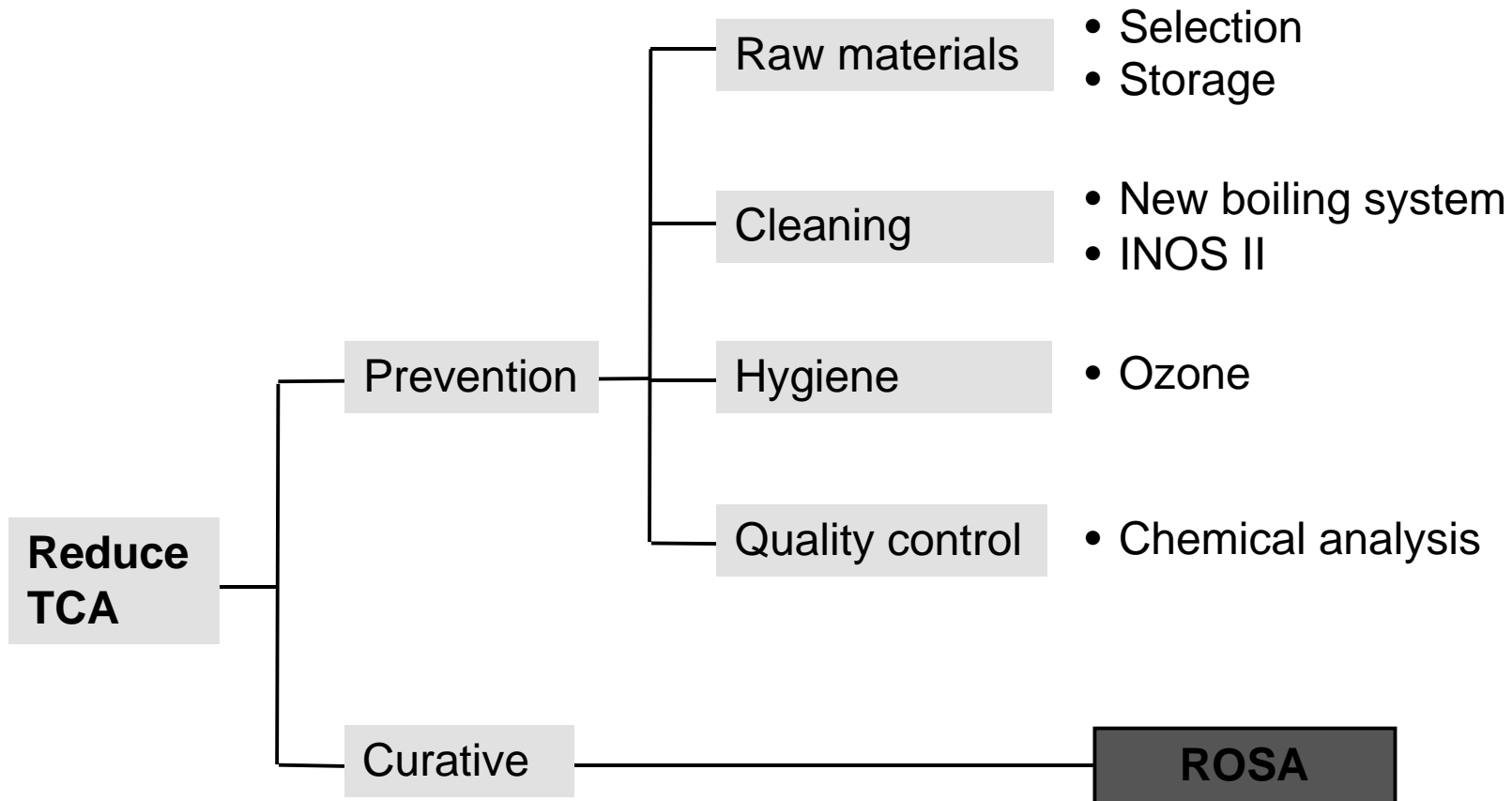



AMORIM

## ROSA GENESIS — BASIC CHEMISTRY

Caution: A STRONG IRRITANT.  
USE: Insecticide.

9758. **2,4,6-Trichloroanisole.** Tyrene.  $C_7H_5Cl_3O$ ; mol wt 211.47. C 39.76%, H 2.38%, Cl 50.29%, O 7.57%. Prepd by reaction of 2,4,6-trichlorophenol with dimethyl sulfate: Kohn, Heller, *Monatsh.* 46, 91 (1925).

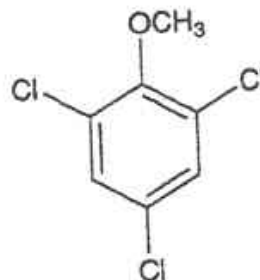

Monoclinic needles from alc, mp 60°, bp<sub>738.2</sub> 240°, bp<sub>28</sub> 132°. Faint odor similar to that of acetophenone. Sublimes slowly at room temp. Volatile with steam. Practically insol in water. Sol in methanol, dioxane, benzene, cyclohexanone.

USE: Formerly as a dye assistant for polyester fibers.

9759. **1,2,3-Trichlorobenzene.** *vic*-Trichlorobenzene.  $C_6H_3Cl_3$ ; mol wt 181.45. C 39.72%, H 1.67%, Cl 58.62%. Prepared from 3,4,5-trichloroaniline by diazotization: Helleman, *Monatsh.* 38, 1005 (1905).

Source: The Merck Index, 12th edition, 1996, p.1642



AMORIM

## 3-YEAR DEVELOPMENT AND VALIDATION OF ROSA

	Laboratory	Prototype 1	Prototype 2	Industrial pilot	Validation	Industrial routine
Granules	■	■	□	■	■	■
Discs	■	■	■	▲	▲	□
Stoppers	■	■	■	▲	▲	□



AMORIM

# ROSA — CONTROLLED STEAM DISTILLATION

PROTOTYPE 1  
CONTINUOUS SYSTEM

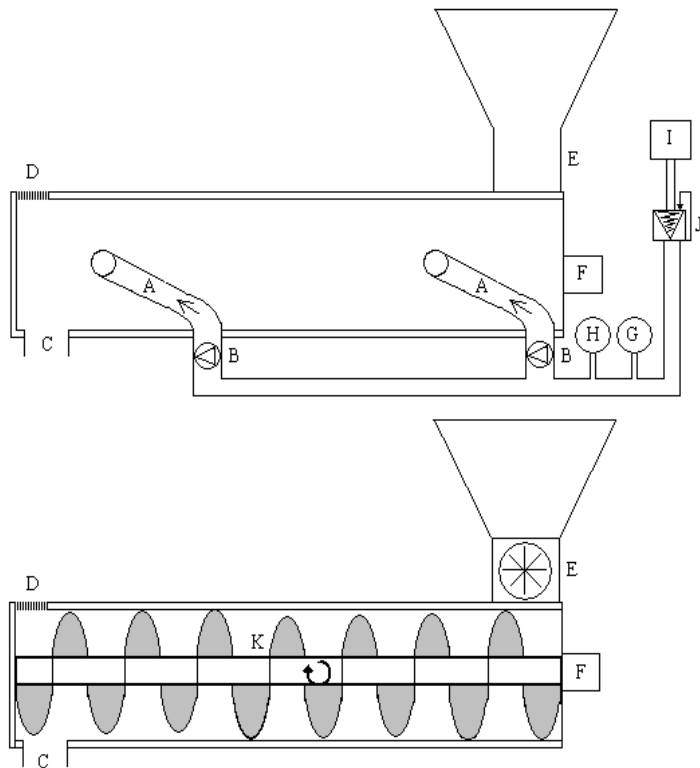

PROTOTYPE 2  
BATCH SYSTEM

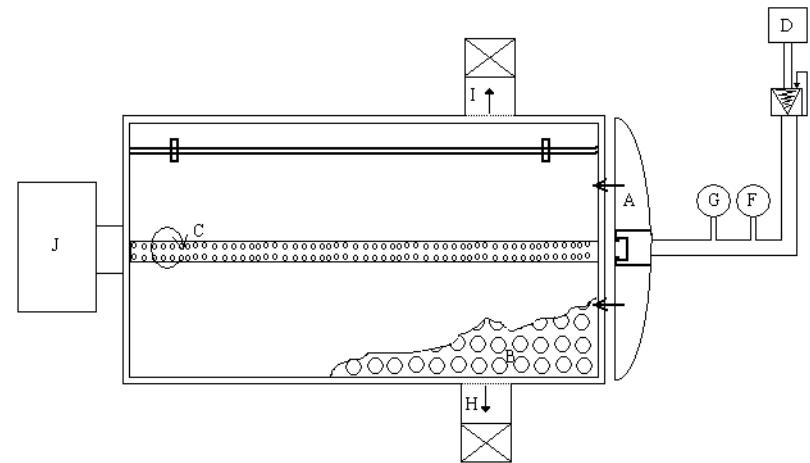



AMORIM

## 3-YEAR DEVELOPMENT AND VALIDATION OF ROSA

	Laboratory	Prototype 1	Prototype 2	Industrial pilot	Validation	Industrial routine
Granules	■	■	□	■	■	■
Discs	■	■	■	▲	▲	□
Stoppers	■	■	■	▲	▲	□



AMORIM

# INTERNAL VALIDATION, INDUSTRIAL PILOT

GRANULES  
Before ROSA After ROSA

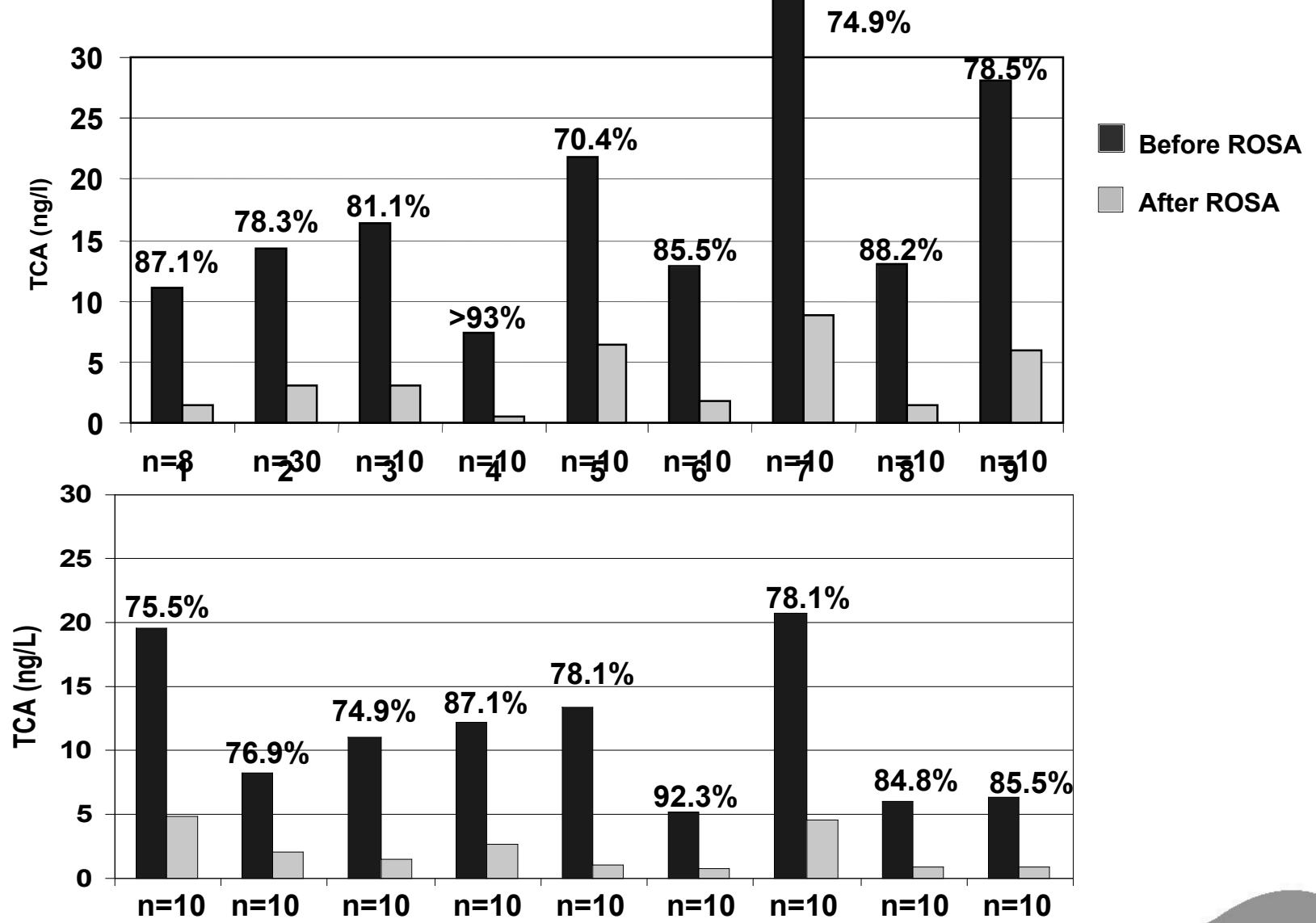





AMORIM

# AWRI VALIDATION, INDUSTRIAL PILOT — GRANULES

■ Before ROSA  
■ After ROSA

Average reduction\*: 69.3%–72.5%

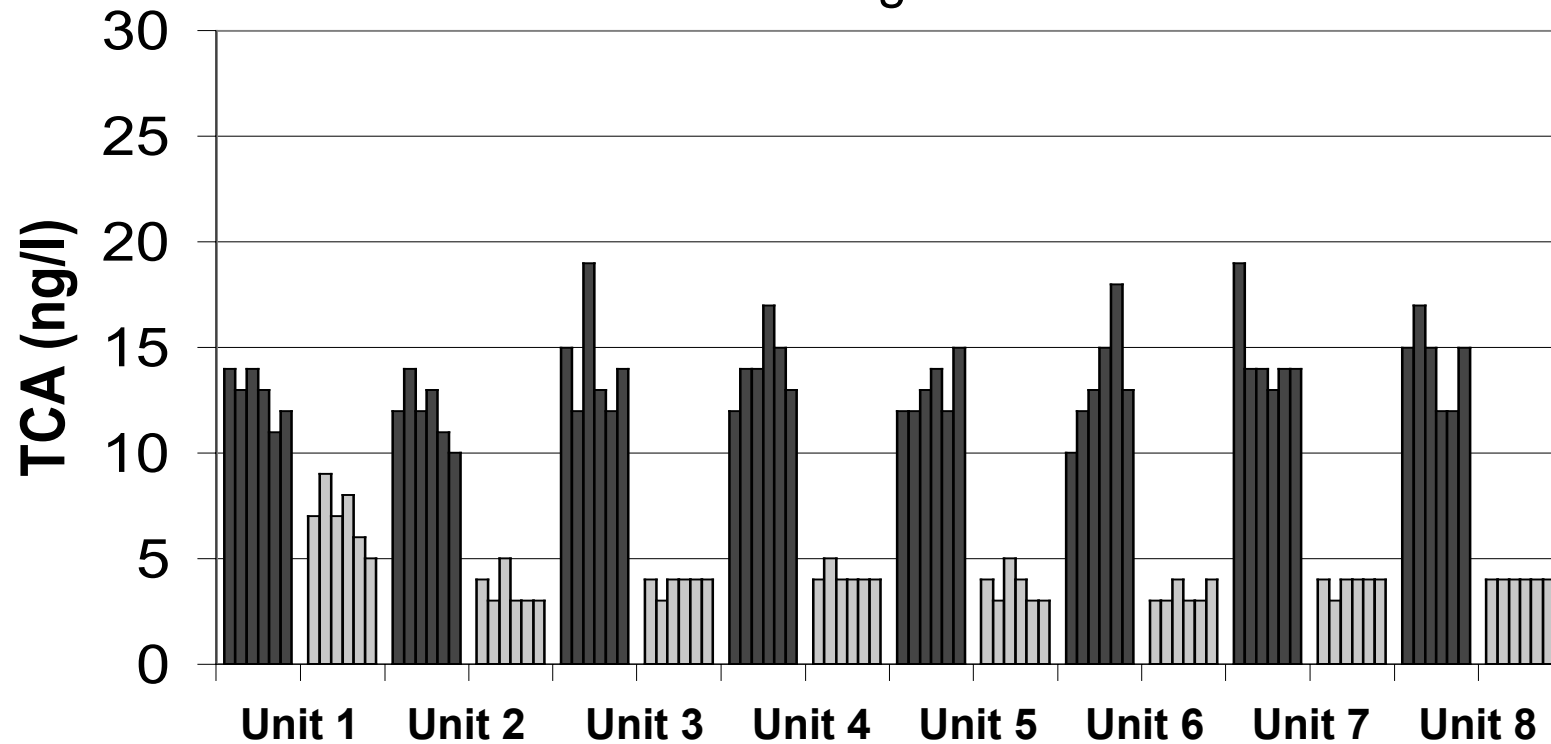

\*Average inc. and exc. Unit 1 results



AMORIM

## SIGNIFICANT REDUCTIONS IN OTHER VOLATILE COMPOUNDS POST-ROSA

MIB (ng/l)

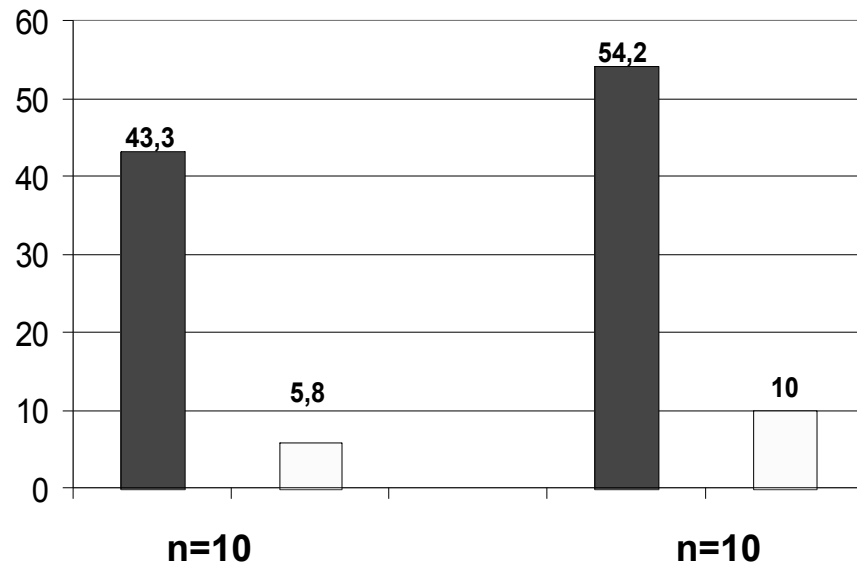

Guaiacol (ng/l)

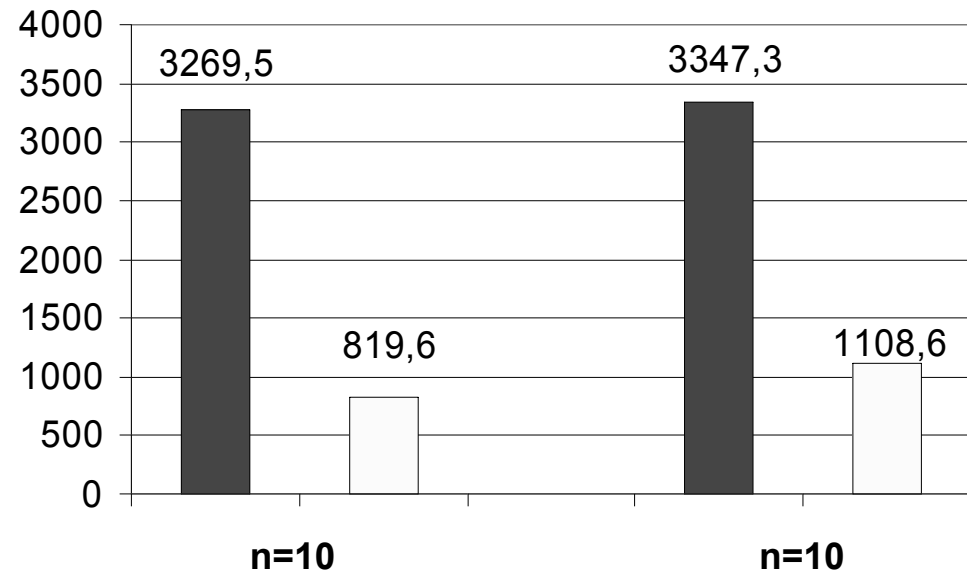

Aroma threshold: MIB = 30ng/l; Guaiacol = 20,000 ng/l  
Amon *et al*, AWIJ, Feb 1989



AMORIM

## ROSA INDUSTRIAL UNIT — CORK GRANULES





AMORIM

## BOTTLING EXPERIMENT, AGGLOMERATE CORK STOPPERS, PROTOTYPE SCALE

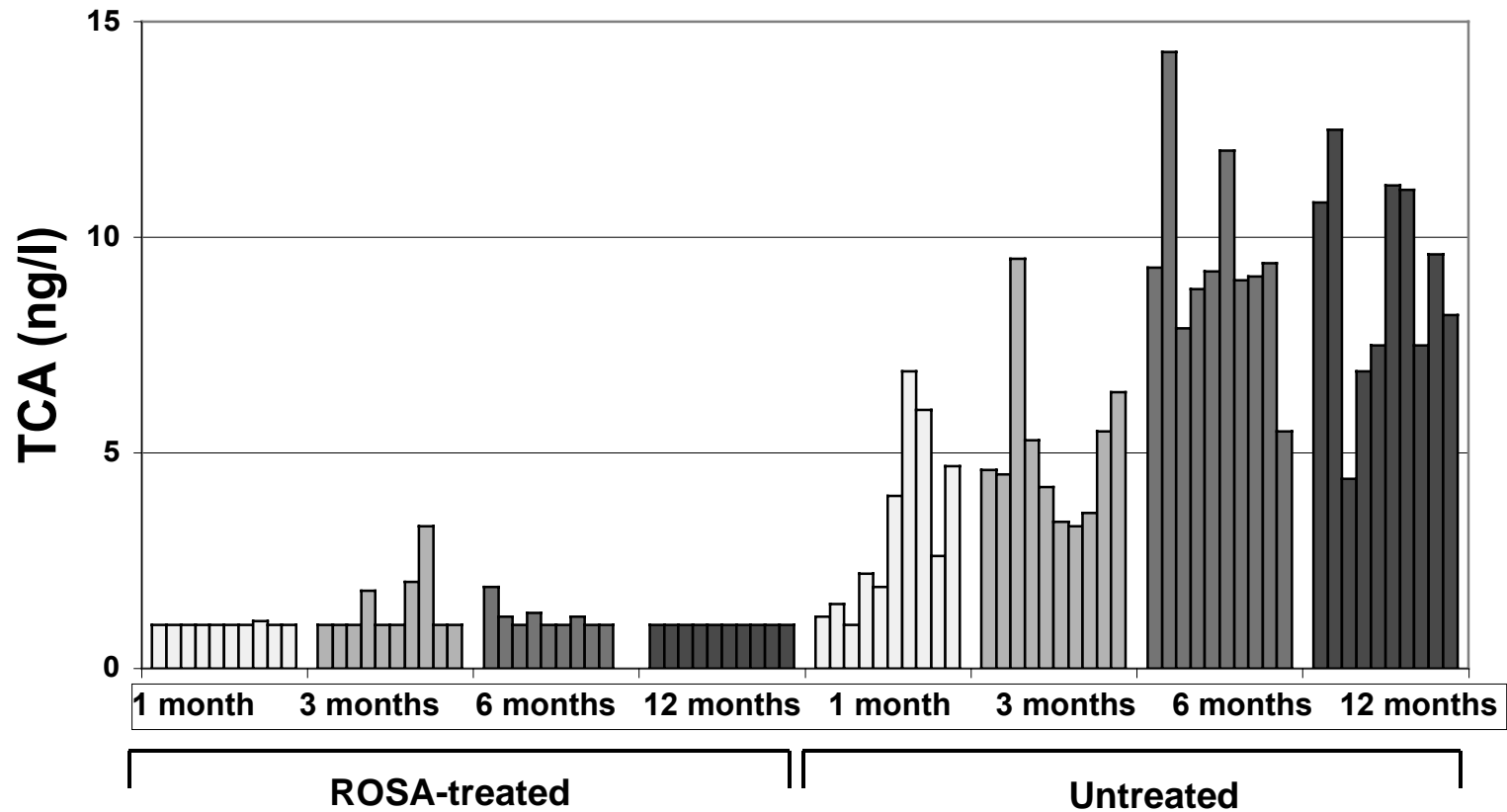



AMORIM

# 3-MONTH BOTTLING EXPERIMENT, AGGLOMERATE CORK STOPPERS, INDUSTRIAL PILOT 1

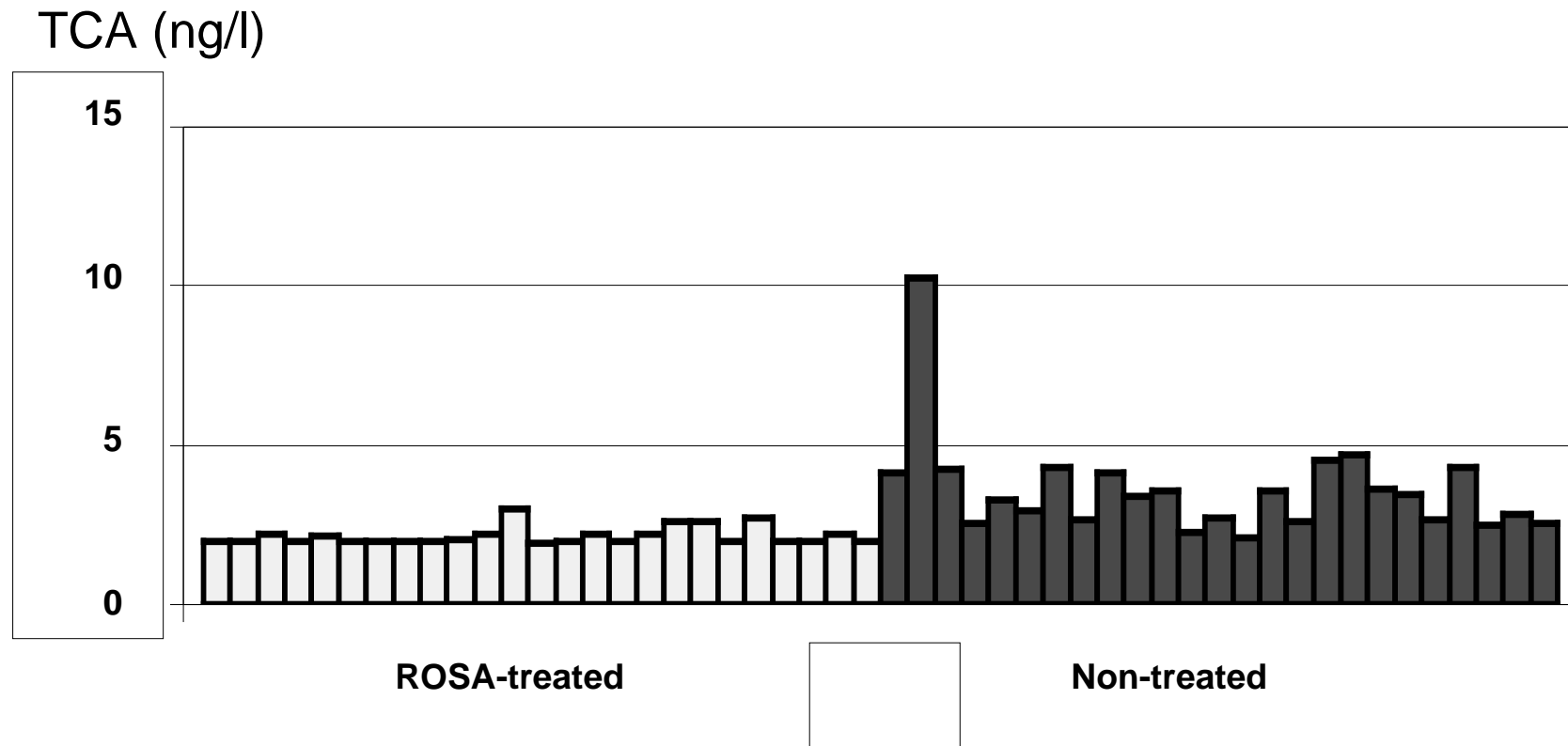



AMORIM

## 3-YEAR DEVELOPMENT AND VALIDATION OF ROSA

	Laboratory	Prototype 1	Prototype 2	Industrial pilot	Validation	Industrial routine
Granules	■	■	□	■	■	■
Discs	■	■	■	▲	▲	□
Stoppers	■	■	■	▲	▲	□



AMORIM

## ROSA INDUSTRIAL PILOT 2, CORK DISCS AND STOPPERS

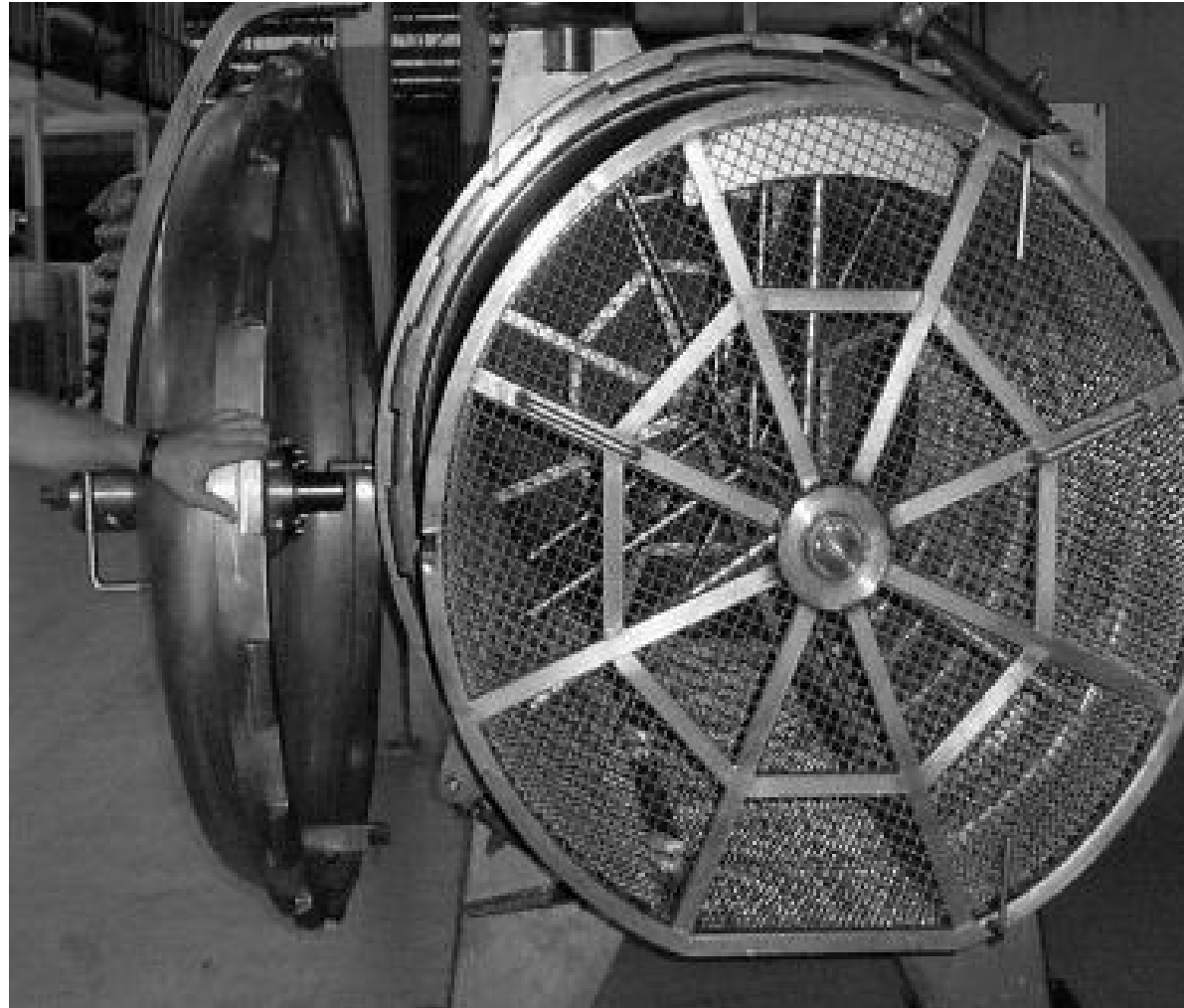



AMORIM

## INDUSTRIAL PILOT, DAILY ROUTINE, CORK STOPPERS

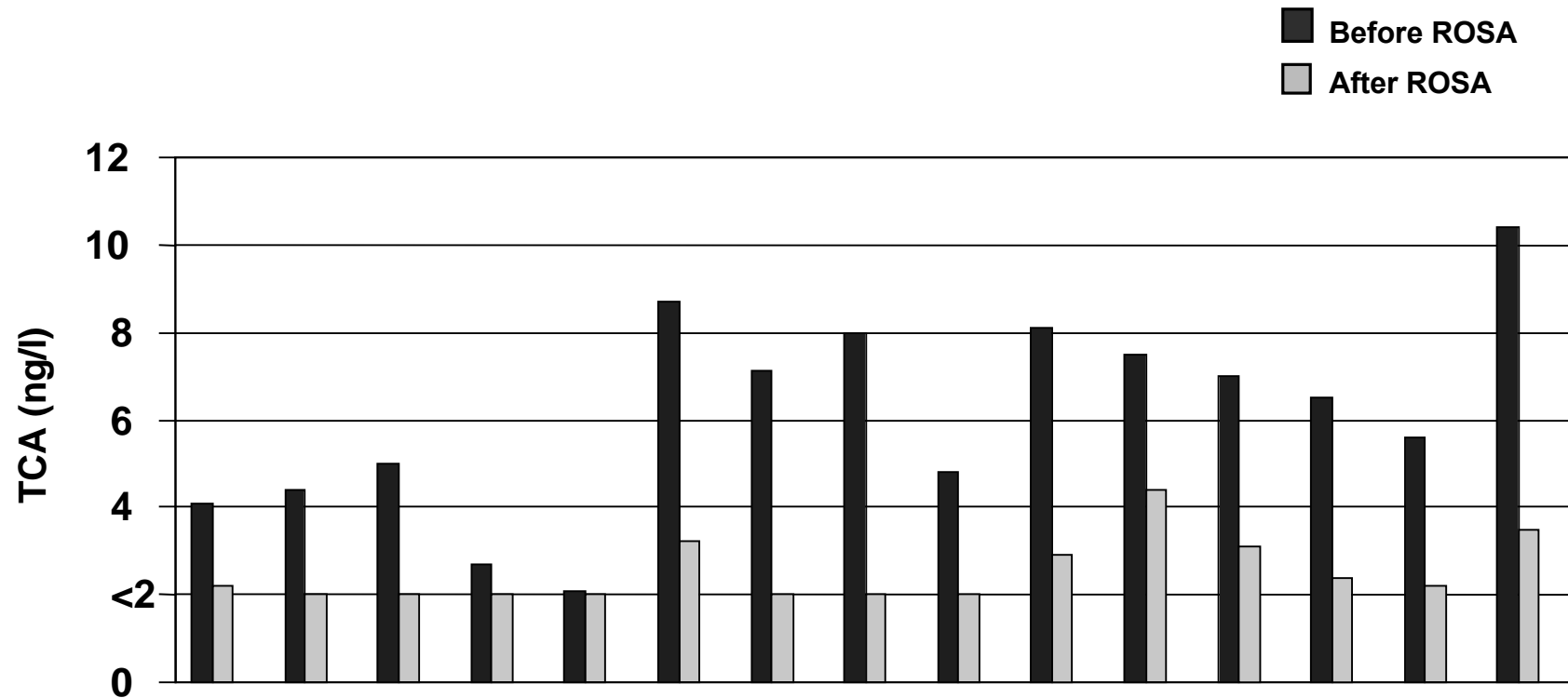

Daily average of 8 samples per unit (composite soak of 50 corks),  
September 2003



AMORIM

# INITIAL EXCELL VALIDATION, INDUSTRIAL PILOT— DISCS AND STOPPERS

Cork discs

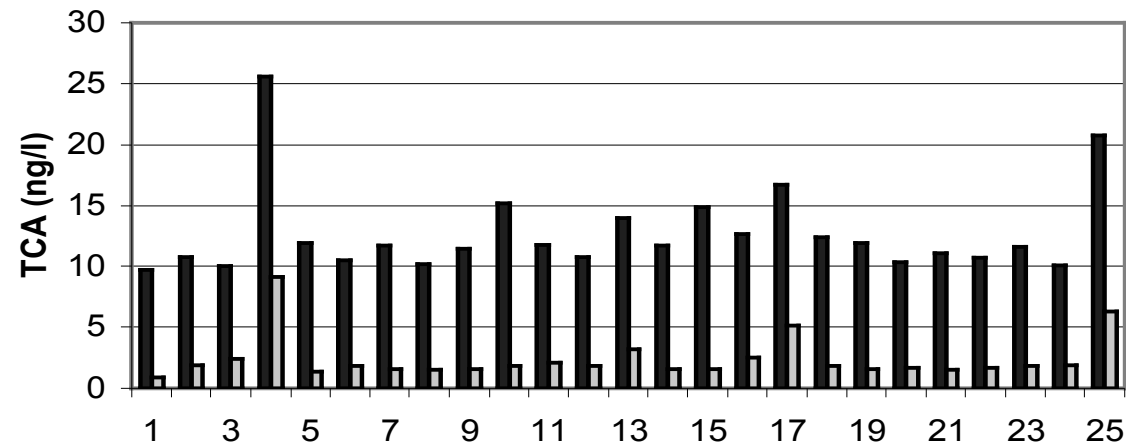

Cork stoppers

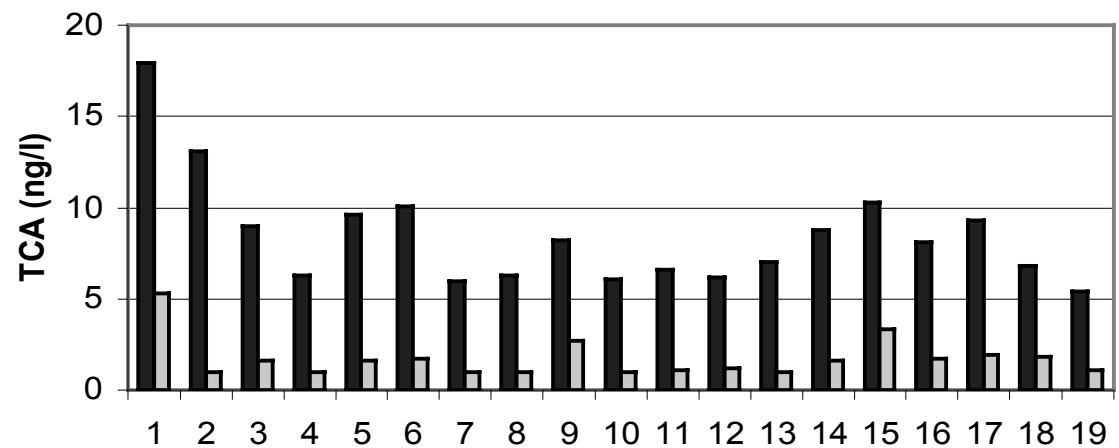





AMORIM

## WHERE TO FROM HERE?

**Commercial production,  
Neutrocork<sup>®</sup> and Twin Top<sup>®</sup>**

**Further development, cork discs  
and stoppers**

**Further validation, cork discs and  
stoppers**



# The ROSA Process

Advances in TCA reduction



AMORIM

Technical presentation by  
Prof. Miguel Cabral  
Director of Research & Development  
Amorim & Irmãos